

*DEMONSTRATED & PROVEN
TECHNOLOGIES FOR OVER
36 YEARS*

**An Environmentally Neutral Critical
Minerals Refinery Network in U.S.**





DEMONSTRATED & PROVEN TECHNOLOGIES FOR OVER 36 YEARS

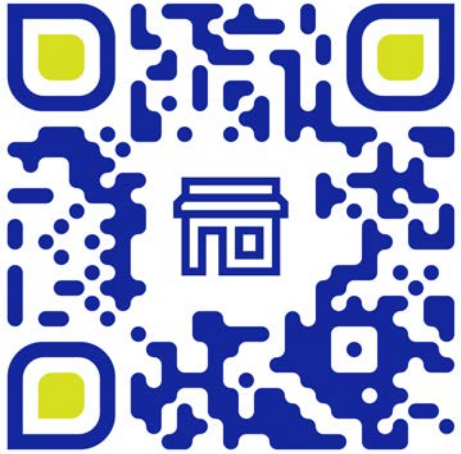

CVMR CORPORATION

U.S. BASED CRITICAL MINERAL REFINERY

tel. +1 (416) 743-2746
email info@cvmr.ca
web www.cvmr-usa.com

35 Kenhar Drive, Toronto,
ON, Canada. M9L 1M9

SCAN ABOVE FOR CORPORATE PRESENTATION
EASILY SAVE CVMR® CONTACT INFO TO YOUR CONTACT LIST

No-Hassle. No Opt-In

Why CVMR®

DEMONSTRATED & PROVEN TECHNOLOGIES FOR OVER 36 YEARS

CVMR's proprietary, environmentally neutral Chemical Vapor Metal Refining technologies have the proven capability to refine rare earth, nickel, copper, cobalt, graphite, graphene, and all other critical minerals into high purity powders and sophisticated materials.

CVMR OVERVIEW

- CVMR has over 36 years of experience in refining metals. We are known to the U.S. Departments of Energy and Defense and several national laboratories engaged in scientific and defense-related research. For a required investment of up to \$5 billion over the next 5 years, CVMR has the capability of establishing an integrated global supply chain to significantly affect strategic and rare earth metals production from mining to concentrating and refining.



CVMR's proprietary, environmentally neutral Chemical Vapor Metal Refining technologies have the proven capability to refine rare earth, nickel, copper, cobalt, graphene, graphite, and all other critical minerals into high purity powders and composite materials.

- CVMR (USA) Inc., ("CVMR") is uniquely positioned to provide a secure source of the critical minerals to the US government and strategic manufacturers such as Pantex, Textron, Lockheed, CNS, Honeywell, Northrop Grumman, Boeing, and General Atomic.

CVMR IS A QUALIFIED SUPPLIER FOR:



Designated
NATO supplier



CVMR® is
ISO 9001 Registered



TSSA Certified
and Approved



Canadian
Department
of Defense



US Department
of Energy



US Bureau
of Engraving



US Mint



Argonne
NATIONAL
LABORATORY
Argonne National
Laboratory



GE Global
Supplier



US DOE-
Oak Ridge National
Laboratory



Department
of Defense



Strem
Chemicals

CAPABILITIES

Technical:

- CVMR's existing global build plan is designed to secure a continuous long term supply chain of refined critical minerals.
- CVMR can refine laterite or sulphide ores more quickly and at lower capital and operational costs than other prevailing refining methods. We produce metal powders, metal nano-powders, metal foams, coatings, complex net shapes, and custom designed super alloys.
- CVMR also produces graphene and graphite from diverse sources – mining, methane gas, and captured industrial CO₂.

Sourcing:

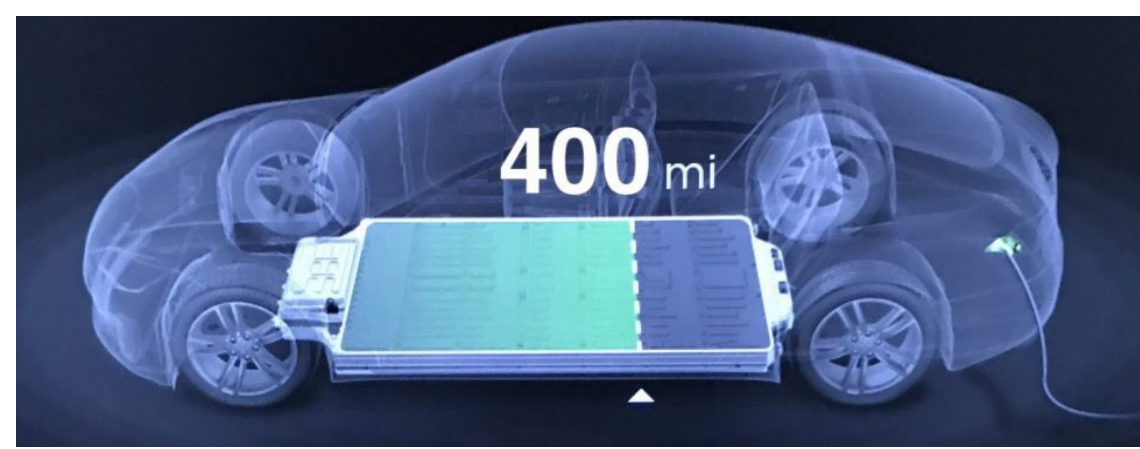

- **CVMR maintains proven mineral reserves rich in 36+ critical minerals including nickel, cobalt, copper, vanadium, and rare earth elements across 18+ countries.**
- Our longstanding relationships with some of the world's most mineral rich nations grant us priority access to raw materials to meet demand surge in the United States.



BACKGROUND: From its inception 36 years ago, CVMR has been engaged in some of the most critical national defense research and innovation, carrying over 70 seminal patents and numerous scientific awards. CVMR's proprietary capabilities have been extended to select clients and continuously held under strict patent protection.



THINGS WE DO NOT DO

-  CVMR's processes DO NOT melt the metals as is done in the smelting processes.
-  CVMR refining processes DO NOT harm the environment. Our processes are environmentally neutral with NO impact on the air, water, or soil.
-  Not only do we NOT produce Green House Gases in our processes we convert such gases to graphene and graphite from industrially produced CO₂, methane gases, and graphite mining resources.



CVMR is building a network of world class metals refineries in the United States capable of processing high value metals including each critical mineral as defined by the Department of Interior and all 17 Rare Earth Elements.

Throughout its 36 years of operations, CVMR has maintained an unparalleled safety record with zero accidents, injuries or environmental hazards.

APPLICATIONS IN THE MODERN WORLD

Technology-critical metals are essential to many current and future energy technologies. They underpin energy systems, transportation, manufacturing and critical infrastructures.

Batteries used in electric vehicles and stationary energy storage systems need **cobalt, nickel and lithium**. Also important are materials such as graphite, used in anodes.



The most efficient electric vehicle motors use **neodymium rare-earth magnets** for efficiency.



Platinum-group metals are essential in a range of industries, including refining, bulk chemicals manufacture, and pharmaceuticals, where they are essential for the manufacture of drugs.



Neodymium rare-earth magnets are used in generators in off-shore wind turbines. Modern large wind turbines can contain up to three tonnes of magnets. This represents an enormous resource that could be harnessed at the end of a wind turbine's lifecycle.



Some hydrogen fuel cells contain **platinum-group metals**. In the future, fuel cells could play a key role in the de-carbonisation of transport, and also can be used to produce heat and power in stationary applications.

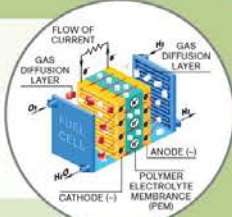

The marine sector will use **neodymium-based rare-earth magnets** in efficient electric drives, together with batteries and fuel cells, all of which contain technology-critical metals.

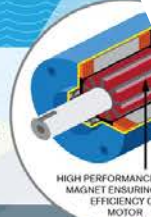

HIGH PERFORMANCE Ni-Fe-B MAGNET ENSURING HIGH EFFICIENCY OF MOTOR

Platinum-group metals are used in the catalytic converters of internal combustion engine vehicles to reduce emissions.



Rhenium is used in superalloys which help to make more efficient, cleaner aircraft engines.



Samarium cobalt alloys will be used in magnets in future electric aircraft engines.



U.S. FOREIGN RELIANCE:

Mineral Commodity Net Import Reliance

The United States is highly import reliant for a large and growing number of mineral commodities

- The U.S. foreign reliance on critical minerals has bolstered Executive Orders and significant congressional interest since the 111th congress, e.g. Executive order 13817
- Critical Minerals are essential to the nation's economic wellbeing and national security.



14 CRITICAL MINERALS

The U.S. is 100% reliant on foreign sources for at least 14 of the 35 critical minerals



16 CRITICAL MINERALS

The U.S. is 50% reliant on foreign sources for another 16 critical minerals



DEMAND INCREASE

The World Bank estimates that demand for metals could increase 10-fold by 2050

The Critical Mineral Global Supply Chain is Fragile

Among other things, the COVID-19 pandemic highlights the fragility of global supply chains and underscores the risks of supply disruptions during a crisis. This is only the most recent reminder of such risks to economies that are heavily reliant on imported goods and materials.

Notable disruptions stem from:

- trade tension
- Resource nationalism
- labor strikes
- natural disasters
- disease outbreak.

China's threats to cut-off rare earth supplies in 2010 epitomized these risks for importing countries who had limited alternatives due to China's near-monopoly of the rare earth supply chain.

This supply risk is dynamic, shifting with changes in global market conditions. A shortage would have catastrophic effects on National Security and new and emerging technologies ranging from electric vehicles to wind turbines.

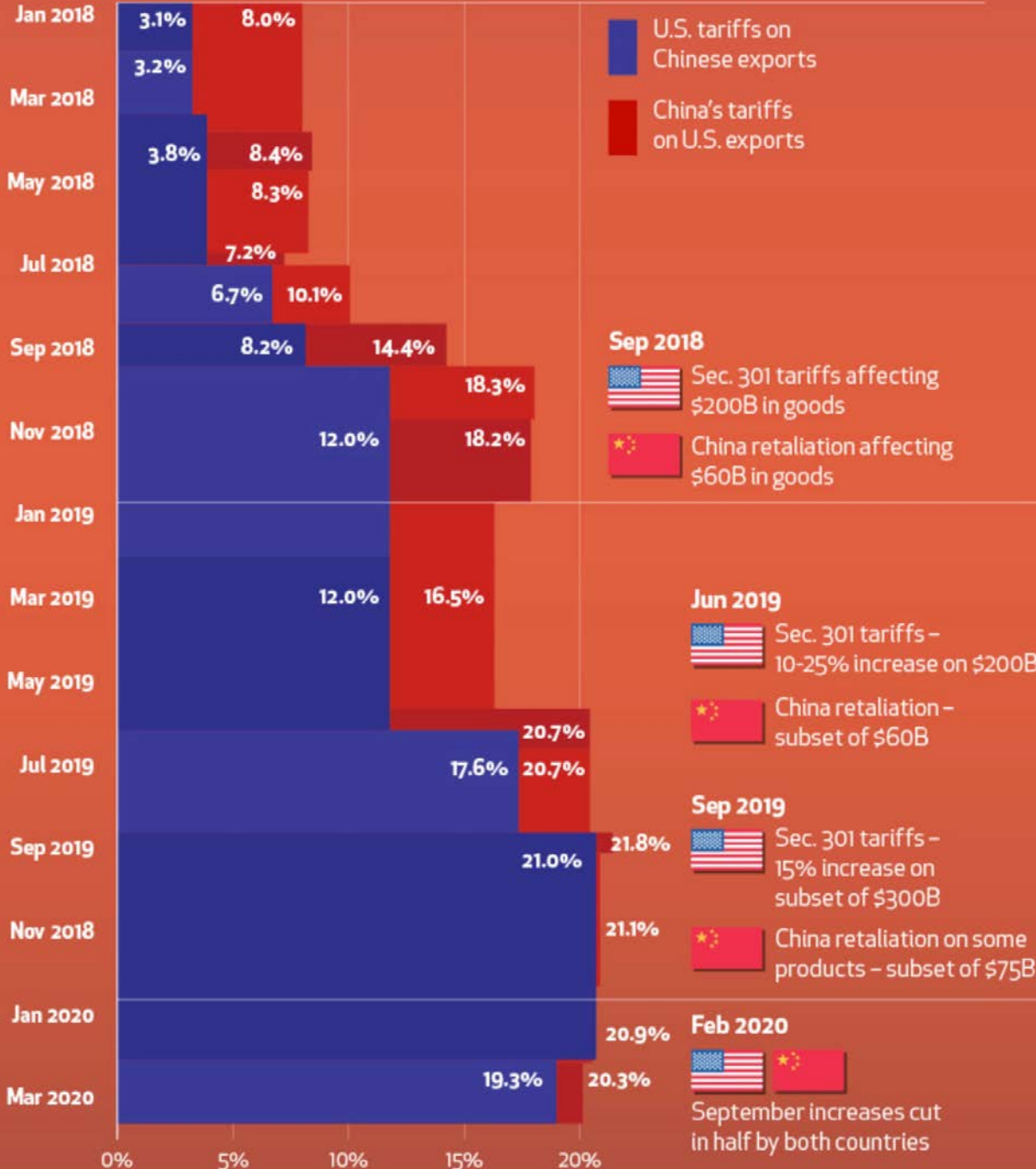



A SUSTAINABLE DOMESTIC SUPPLY OF CRITICAL MINERALS



Achieving a Core National Security Objective by building an environmentally neutral Critical Minerals Refinery Network in U.S.

- Mined & concentrated mineral ores require final refining.
- China currently controls this final step in the minerals supply chain.



END RELIANCE ON CHINA



CVMR can be an effective force in reinstating U.S. as the dominant global supplier.

Refined minerals for US Defense Industrial Base & Clean Energy Transition.

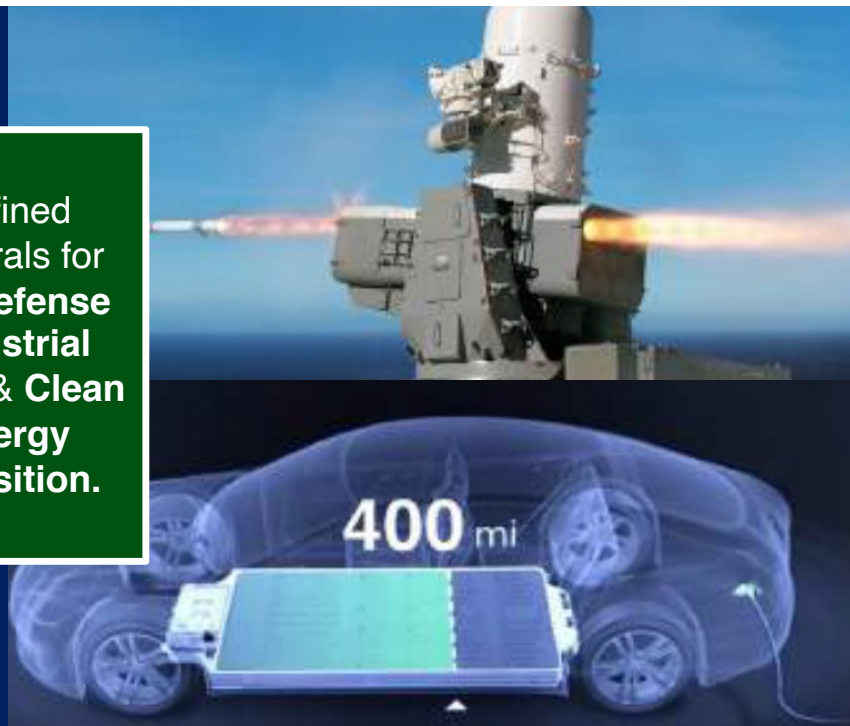

Critical Minerals Market



The Energy Act of 2020 defines “critical minerals” as the minerals, elements, substances, or materials that “(i) are essential to the economic or national security of the United States; (ii) the supply chain of which is vulnerable to disruptions (including restrictions associated with foreign political risk, abrupt demand growth, military conflict, violent unrest, anti-competitive or protectionist behaviors, and other risks throughout the supply chain); and (iii) serve an essential function in the manufacturing of a product (including energy technology-, defense-, currency-, agriculture-, consumer electronics-, and healthcare-related applications), the absence of which would have significant consequences for the economic or national security of the United States” (Public Law 116–260, section 7002(c)(4)(A)).

Methodology and Technical Input for the 2021 Review and Revision of the U.S. Critical Minerals List

<https://pubs.usgs.gov/of/2021/1045/ofr20211045.pdf>

U.S. IMPORTS 76% OF GLOBAL PRODUCTION

• 178,481 tonnes in Q2’21.

24%

FOR THE REST OF THE WORLD

STEADY GROWTH FOR DECADES TO COME

The volume of critical minerals flowing into the country in the first half of 2021 surpassed the 316,108 tonnes imported in the first six months of 2020 by 41,209 tonnes.

NEW CLIMATE GOALS: A BELOW 2°C FUTURE

- The more ambitious climate targets become, the more minerals and metals will be needed for a low carbon future.
- **Over 3 billion tons of metals and minerals will be needed by 2050** to scale wind, solar, and geothermal power and energy storage to reach a below 2-degree Celsius future.

EXECUTIVE & CONGRESSIONAL ORDERS CALL FOR GREATER INVESTMENT

This is a Bi-Partisan issue that has been supported by multiple administrations

June 8th, 2021

President Biden’s administration released a 100-day review of supply chains and **called for greater investment in "sustainable domestic and international production and processing of critical minerals,"** with a particular emphasis on pivoting away from "adversarial nations" such as China

2025 SUPPLY DEFICIT

- **Nickel & Cobalt headed to a supply deficit by 2025**
- It is predicted that by 2050 the EU will require 60 times more lithium, 15 times more cobalt, and ten times the amount of rare earths compared to the current supply to the whole EU economy.

Industry Advantage

CVMR is the only Strategic Metal producer that satisfies consumers growing demand for a fully green supply chain.

- **CVMR's patented Vapour Metallurgical Technology is the most effective and environmentally neutral technology, WITH NO IMPACT TO THE ENVIRONMENT**
- **Other Industry Peers are using technologies reliant on heat, smelting, and harmful elements.**
 - Pressure Acid Leach
 - Heap Leach Processing
 - Solvent Extraction
- **We are often misled by claims that the old processes are environmentally friendly. Yet most metal refineries still produce the following:**
 - NUF-Scheduled Waste
 - Large Amounts of acidic and basic waste solutions containing Cations and Complexing Agents
 - Toxic Materials
 - Corrosive Materials
 - Radioactive materials
 - Significant energy consumption due to lengthy refining process



OTHER
INDUSTRY PEERS

Currently Operating: Capable of Refining Critical Minerals	✓	✗
Refining Capability up to 99.9999% in Purity	✓	✗
Zero Impact to the Environment (Land, Air, Water)	✓	✗
Capability to Refine all 36+ Critical Minerals	✓	✗
Exports mined feedstock overseas for refining (to China and then re-import)	✗	✓
Lowest Operation Costs to refine critical Minerals	✓	✗
Flawless safety record—extending beyond 36 years.	✓	✗
Modular construction enabling Producer to Scale with Demand	✓	✗



ENVIRONMENTALLY NEUTRAL

Our refining technologies are environmentally neutral without affecting the air, water, or soil.

Why CVMR®

ENVIRONMENTALLY NEUTRAL

Our refining technologies are environmentally neutral without affecting the air, water, or soil.

Vapour Metallurgical Technology

CVMR Refining Processes

*DEMONSTRATED & PROVEN TECHNOLOGIES
FOR OVER 36 YEARS*



- CVMR has been licensed to operate its facilities in US.
- Ongoing discussions with the US Department of Energy and defense including government contracts with CVMR to supply critical minerals to the national stockpile.

We are currently operational.

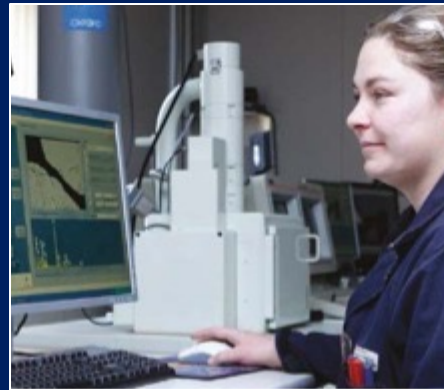

The proprietary vapour metallurgy processes used by CVMR refines various metals by chemically vaporizing them close to atmospheric pressure and relatively low temperatures. CVMR's processes do not melt the metals as is done in the usual smelting processes. CVMR's plants are pollution-free and completely neutral to the environment. They create no air, water or soil pollution of any kind. CVMR's plants are hermetically sealed, and all gases used in its various processes of vapourizing the metals are recycled.

EXAMPLE

CVMR Production Flow

Magnesium Process Flow

The most environmentally friendly metal refining process awarded by the governments of Canada and the United States

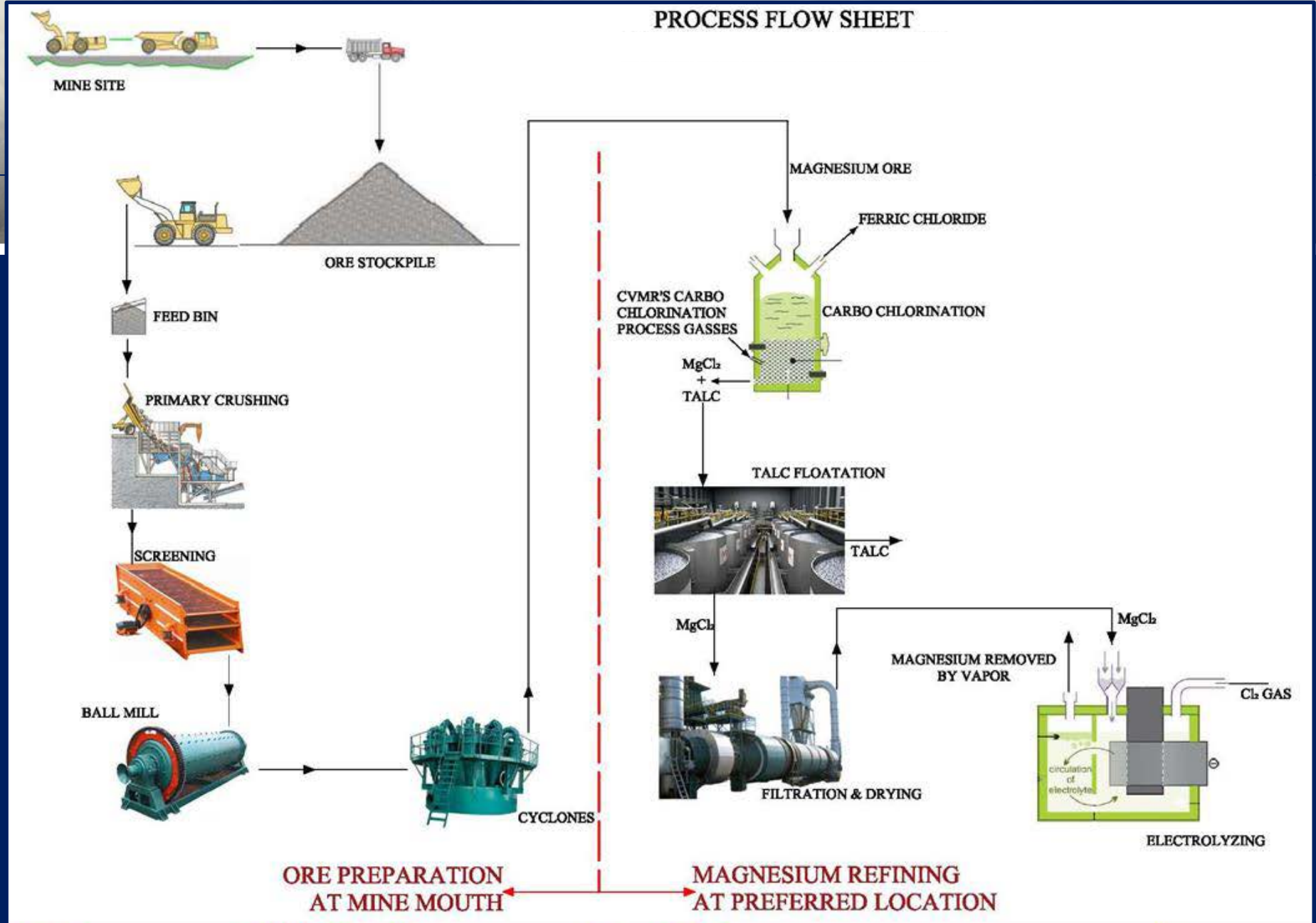

EXAMPLE

CVMR (Iron) Processing Plant Layout

GENERAL LAYOUT FOR VAPOR METALLURGICAL PROCESS

Single Module-Iron Carbonyl Plant

CVMR uses metal ore concentrates to produce products that have a very high value in the market, such as high purity nickel, iron, magnesium, rare earth elements (REE), vanadium and their related alloys, in the form of powders of various morphologies, nano-powders, net shapes (complex shapes) and super alloys, metal powders that are used in 3D printing, additive manufacturing, metal injection molding (MIM) and other new methods of metal extrusion molding. All such products and manufacturing processes are currently used in the production of automotive parts, computer and electronic parts, molds and tools, sophisticated net shapes for use in the defense and space industries, medical instruments, pharmaceuticals, and as supplements in the food industry.

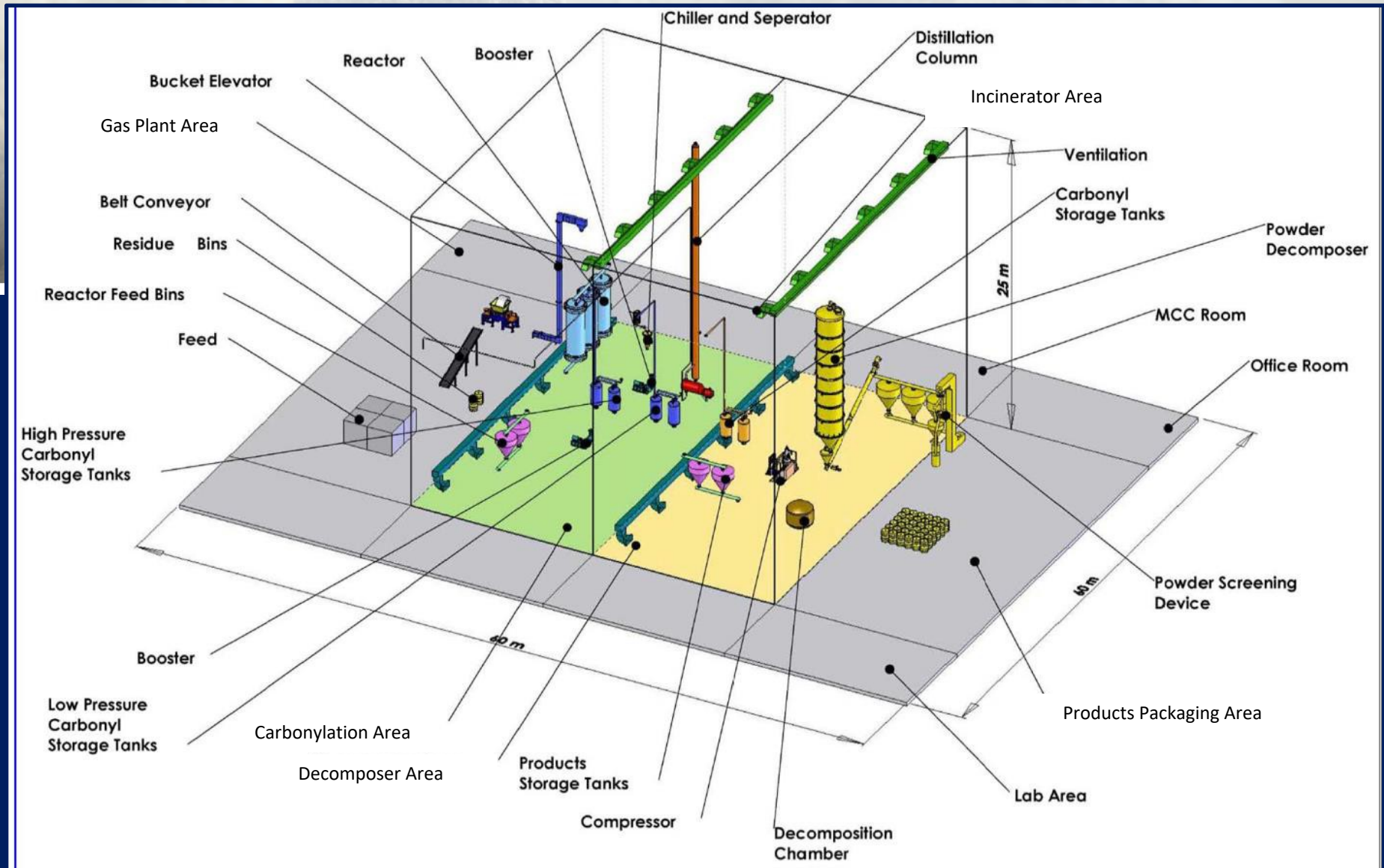

EXAMPLE

CVMR Processing Plant Equipment



BLENDING MACHINE



MIXING BIN

VAPOR METALLURGICAL COMPONENTS

Equipment Used



DRYING MACHINE



PELLITIZER

[cvmr]
U S A

EXAMPLE

CVMR VAPOR METALLURGICAL COMPONENTS



CVMR Recycling of Energy Metals



CVMR®'s Recycling of Energy Metals

Applicable for all critical minerals and Rare Earth

In accordance with CVMR®'s corporate policy to prevent pollution and overuse of natural resources, CVMR® has developed a host of new technologies capable of recycling batteries, including their casings, and various metal parts of various manufactured automotive and aerospace components.

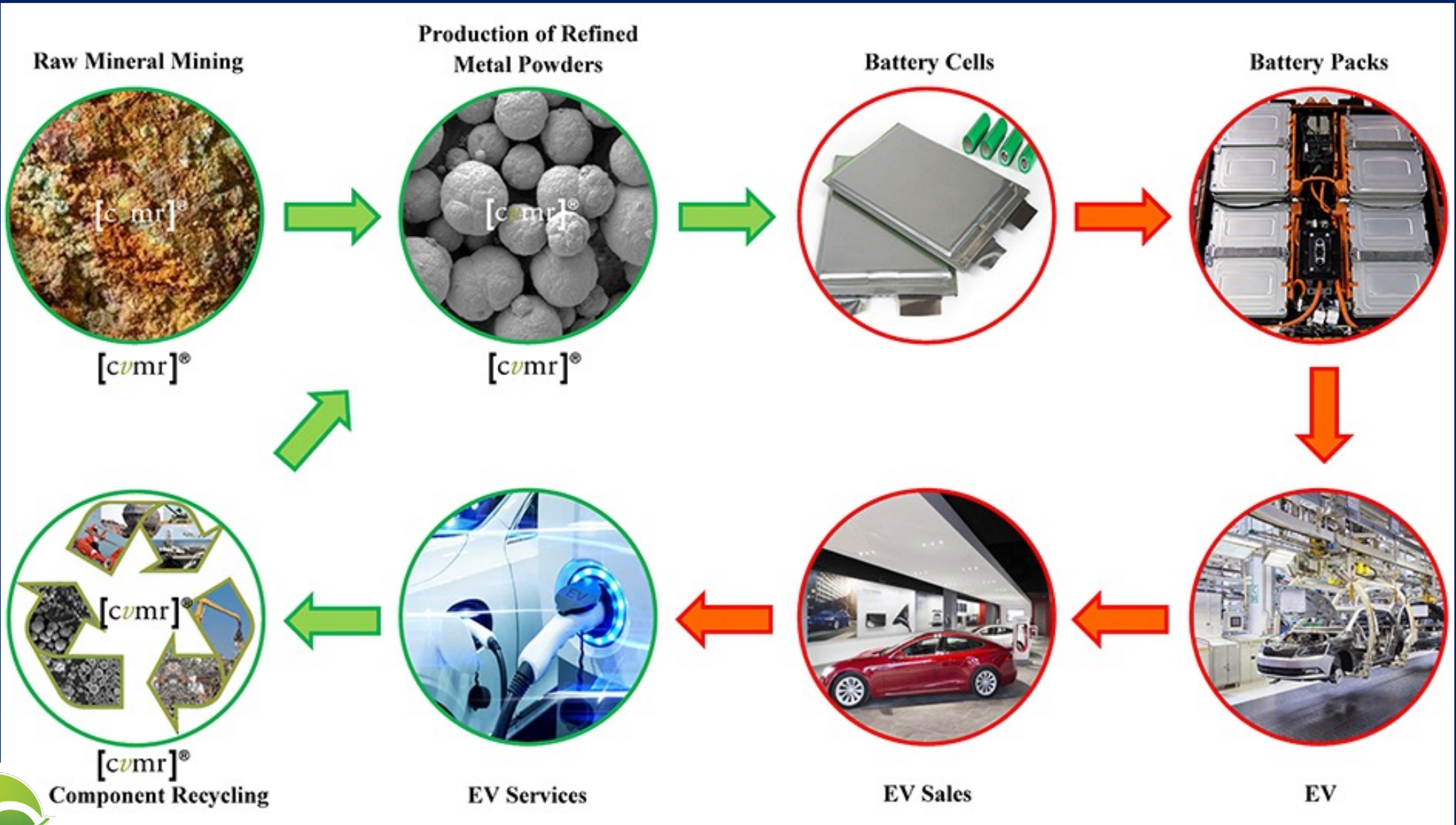

EXAMPLE

CVMR VAPOR METALLURGICAL PROCESS

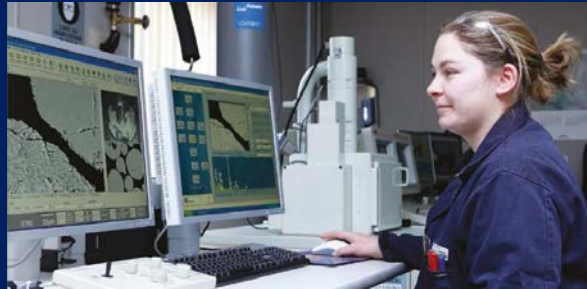

CVMR®'S Toronto Plant

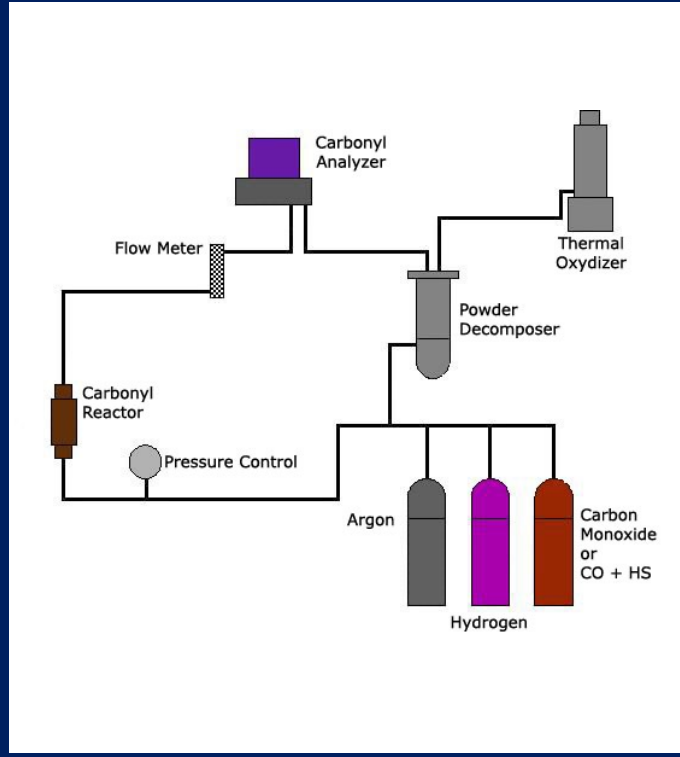
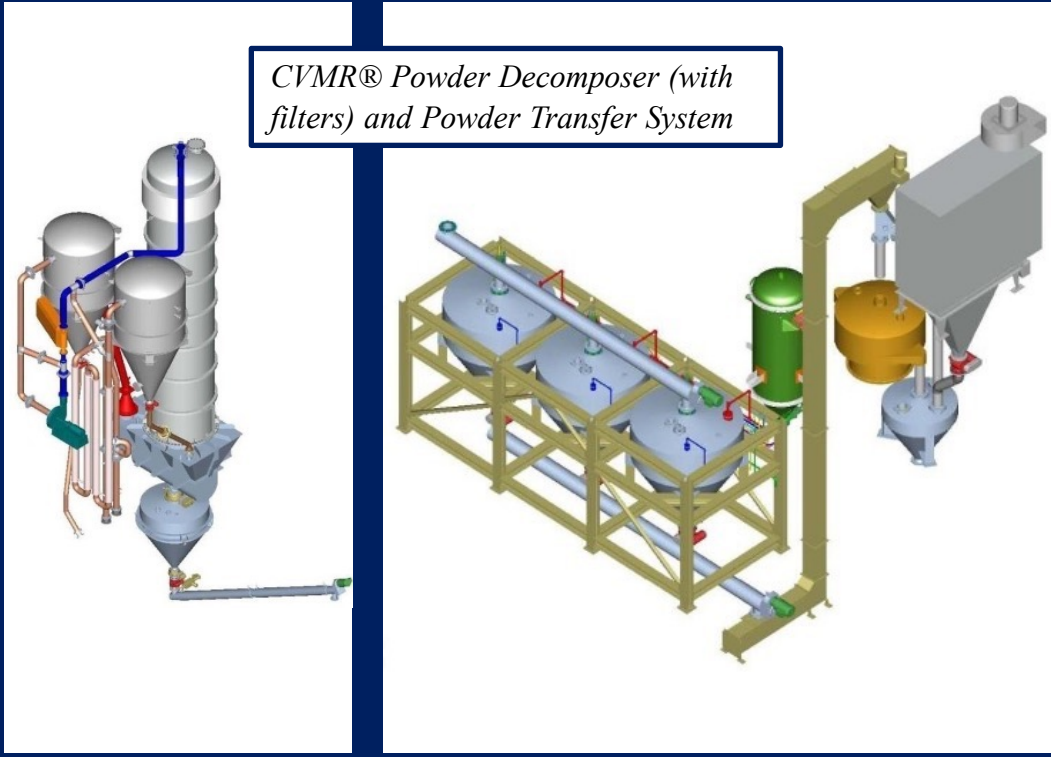





RESERVES & SUPPLY CHAIN

CVMR is expanding its refining capacity to meet various industrial requirements across multiple locations in the US. Each facility will be built in modular, scalable format which can be calibrated to refine different minerals to adapt to industrial requirements.

Current Proven Mineral Reserves:

- Rare Earth Elements (over 12 million MT)
- Nickel (230 million MT)
- Magnesium (over 100 million MT)
- Niobium (48.4 million MT)
- Tantalum (350 million MT)
- Cobalt (30 million MT)
- Copper (128 million MT)
- Vanadium (20 million MT)

	Current Operations
	Planned Refinery Locations
	Existing Refinery Locations
	CVMR Owned/Affiliated Reserves
	Port Location

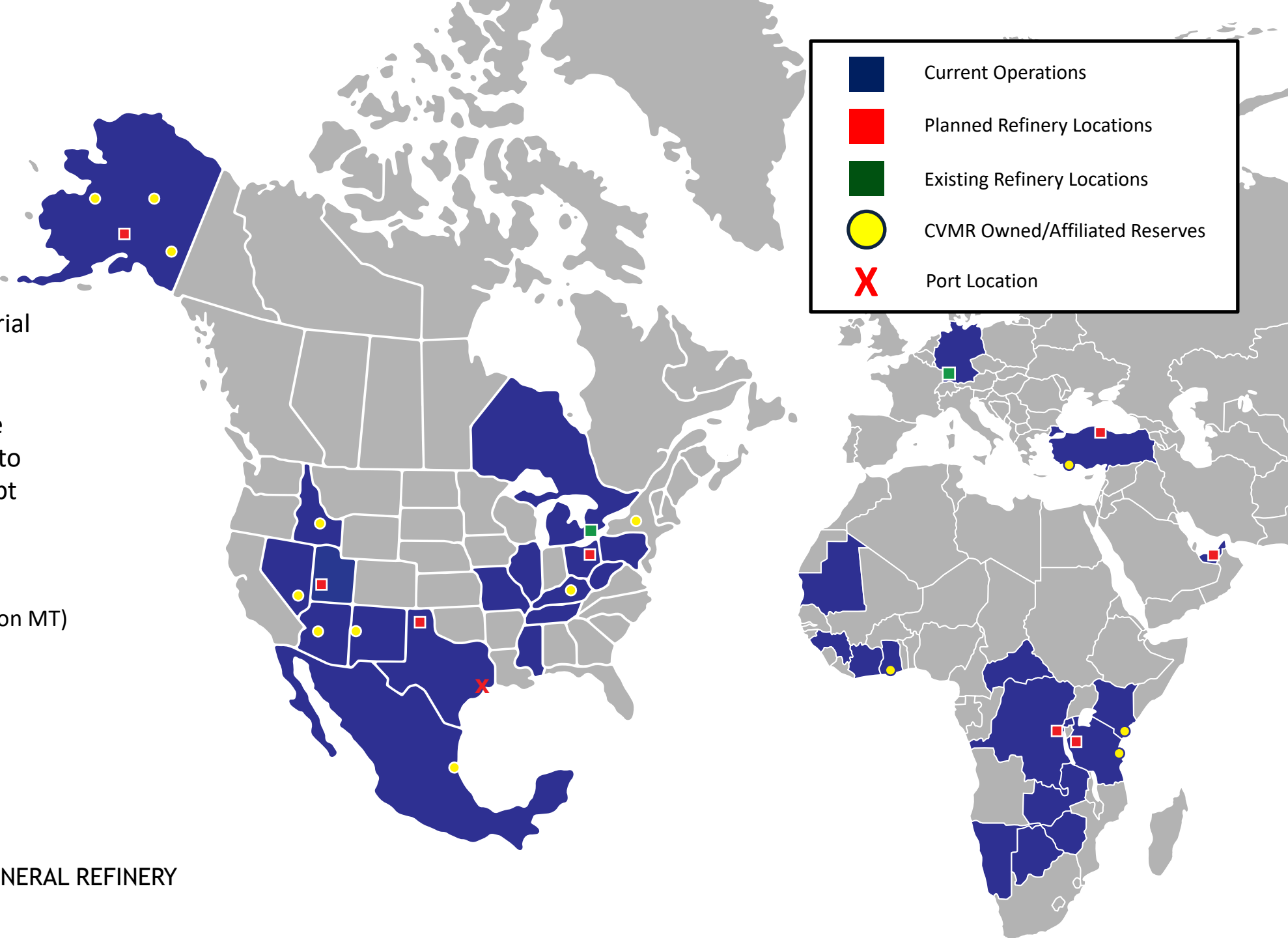

CVMR PRODUCTS

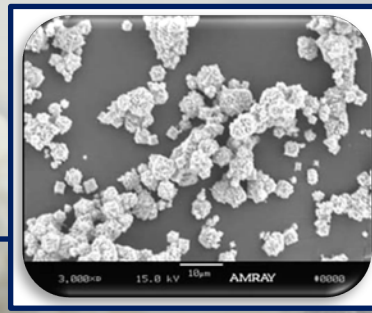

Nickel Powder

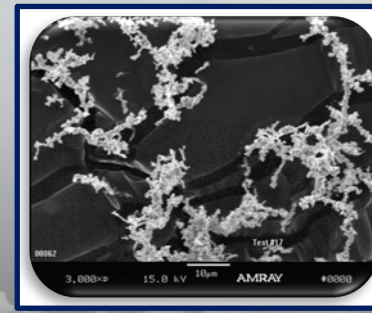

Ferronickel Powders

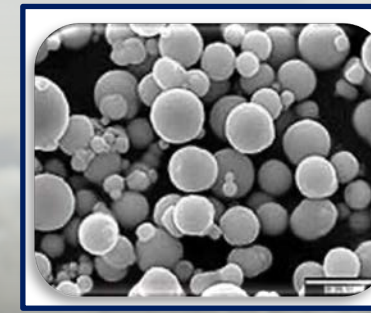

Carbonyl Iron Powders (ICP)

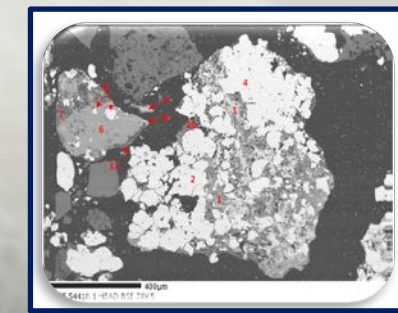

Rare Earth

CVMR® is a provider of proprietary, environmentally neutral, metal refining technologies and a supplier of high value refined metal powders and nano-powders to the automotive, aerospace and electronics industries.

The metal powders produced by CVMR® are used in rechargeable EV batteries, manufacturing of automotive parts, net-shapes and super alloys. Various metal powders produced by CVMR, such as nickel, iron, cobalt, copper, and REE, can be formed into highly complex shapes by Metal Injection Molding (MIM), 3D printing (additive manufacturing), or sintering processes.



AVAILABLE NOW

Products Available for Pre-Order

CVMR is deliberately positioned to support the strategic needs of aligned governments and corporations.

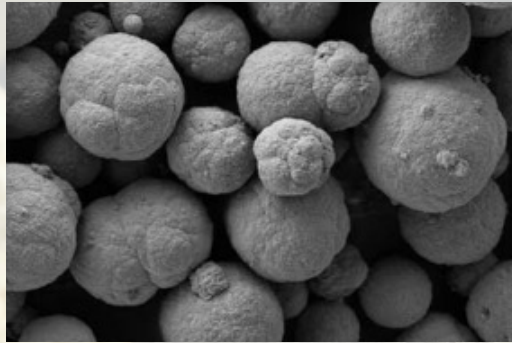

POWDERS

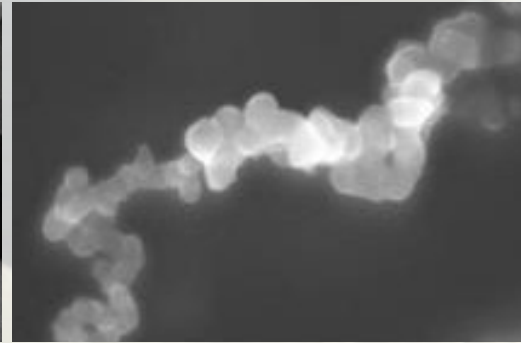

NANO POWDERS

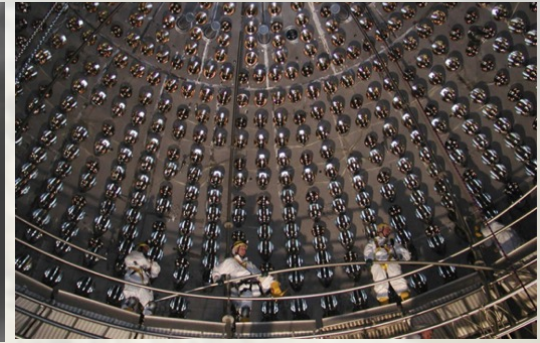

COMPLEX SHAPES (SNO Complex)

Our Current Product Offerings Are In High Demand For The Following Elements

CVMR's processes and technologies have many applications that serve a variety of industries. Our Product Development team utilizes proprietary processes and technologies to make unique custom products from metal powders to finished goods, ready for the end-user.

Highest Purity Powders up to 99.9999%.
Refining with Zero Impact on the Environment
BEST MARKET PRICE

Ni
Nickel

Mg
Magnesium

Li
Lithium

Ta
Tantalum

Co
Cobalt

Cu
Copper

V
Vanadium

REE
Rare Earth

Sustainable High Purity

Graphene

Graphite

Produced through CVMR's proprietary net-zero technology

Why CVMR®

SECTION 03

REFINING FOR THE SECURITY OF OUR NATION

25,000 tpa Nickel Carbonyl Powder processing : Amorillo, TX Planned Plant

- **Water Requirements:**
 - *5,000 m³ per year.*
 - *Water is mainly required for cooling processes and the cooling water will be recycled. Other usages of water are washing out the dust and passivation.*
- **Electricity requirements:**
 - *12mW installed power.*
- **Gas requirements:**
 - *211 MMcf per year.*
- **Wastewater:**
 - *No process wastewater.*
- **Dedicated railroad access**
 - *Dedicated railroad access required*
- **Airport**
 - *Airport within 20 miles that can handle transport cargo aircraft.*
- **Waste/byproduct requirements of process**
 - *A transloading facility would be sufficient.*
 - *There will be no Waste/byproduct.*
- **Land Requirement**
 - *300+ acres for the battery of the refining plant.*

SITE LAYOUT



SITE LAYOUT

CENTER OF EXCELLENCE

OFFICE

Graphite

Nickel

Iron

REE

[cvmr]
U S A

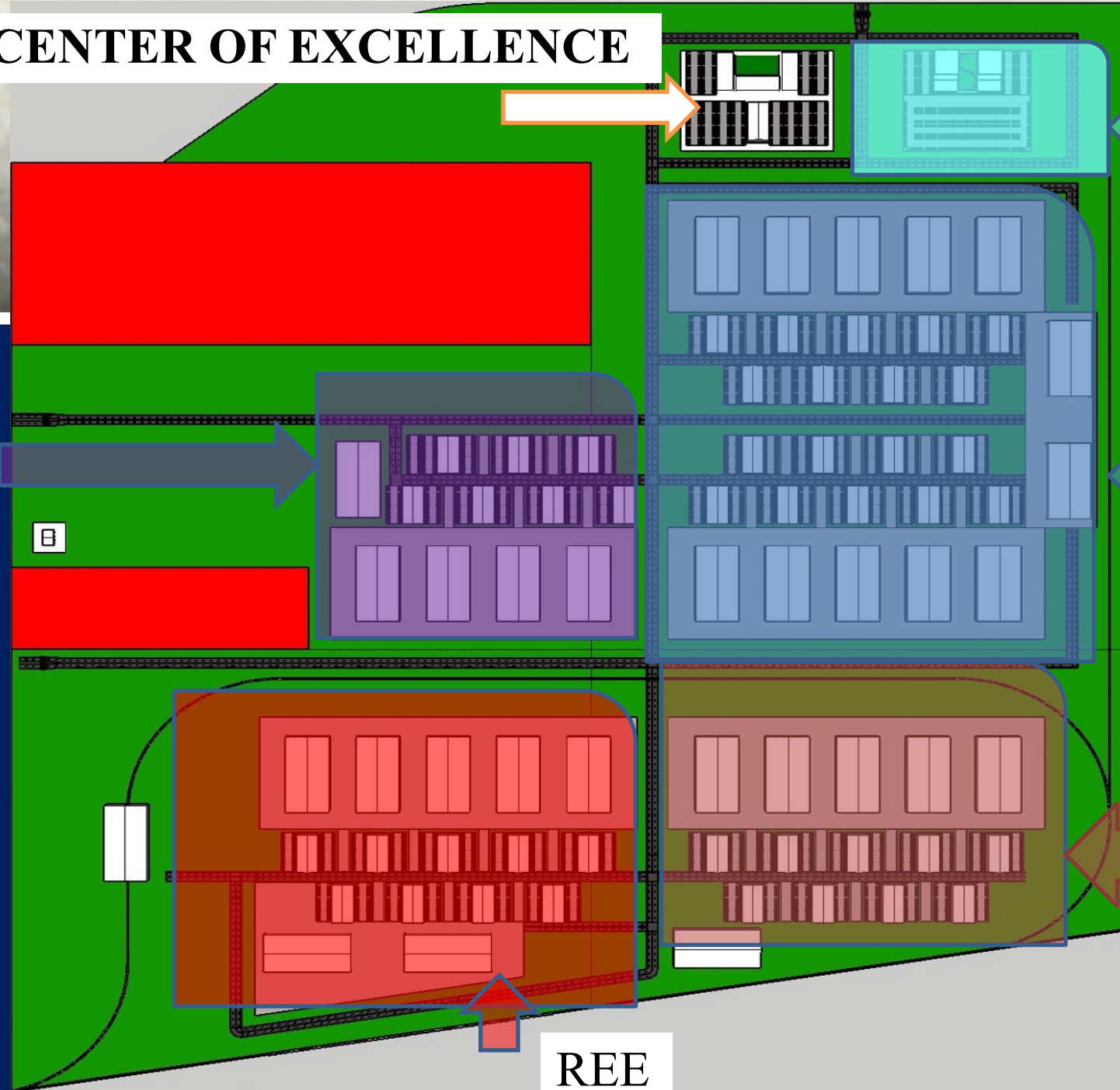

SITE LAYOUT

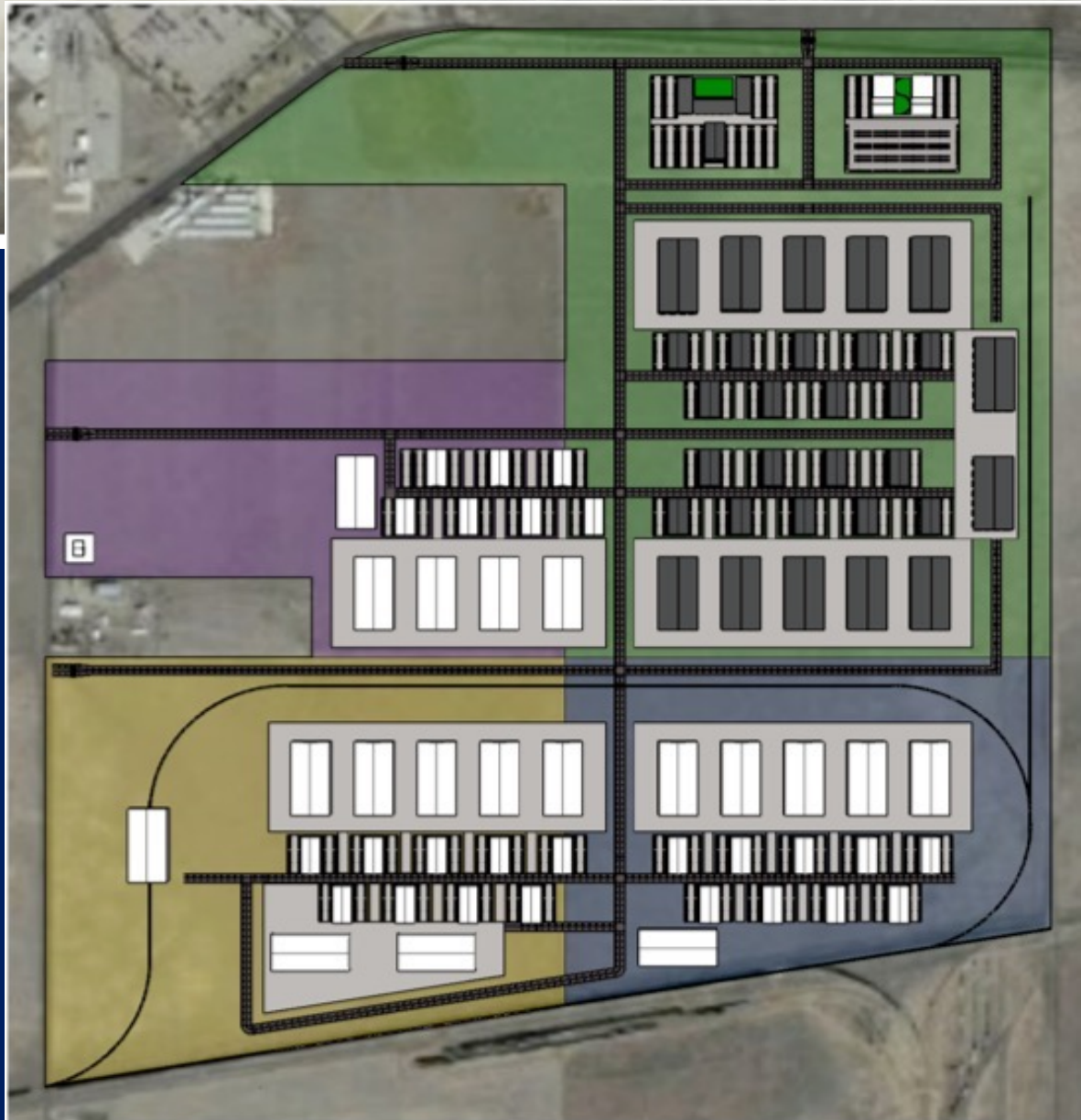

COLOR	PARCEL ID	ACREAGE
PURPLE	200051040500R	85.57
GREEN	200051030000R	227.38
YELLOW	200052010500R	127.73
BLUE	200052020000R	97.53

ABILITY TO SUPPORT U.S. SECURITY

- Construction can start immediately.
- The first phase of the refinery Ribbon cutting (Groundbreaking) within 14-18 months of the funding.
- Several sites in the United States have been identified as suitable for the location of the refinery, Amarillo is our primary choice.
- The entire management team is in place to execute the project.
- The identification of all needed major contractors and suppliers has been completed.
- The cost of the first phase of the project is \$500 million.
- The first phase of the refinery can produce 25,000 tons per annum. (tpa) of nickel powder to be increased within 5 years to 100,000 tpa.



Cutting-edge metals refining technologies for high-te

EXECUTIVE TEAM

cvmr

SECTION

04

C O R P O R A T I O N

Why CVMR®

EXECUTIVE TEAM

CVMR Directors

For Full Management Team and Bios Visit:

<https://cvmr-usa.com/management.php>

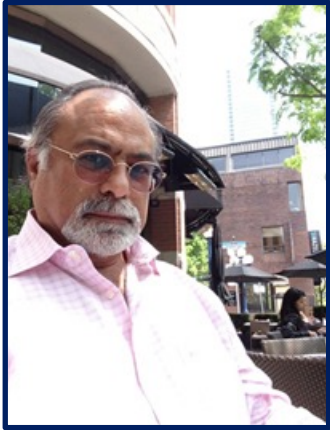

Kamran M. Khozan

Kamran M. Khozan is the Chairman and CEO of CVMR® Group of companies, and founder and major shareholder of a number of highly successful multinational corporations.

Mr. Khozan is the Chairman of Secure Environment Services (“SES”), a leading provider of homeland security, non-weaponry defense equipment and risk management systems, manufactured at its own facilities in North America and Europe, as well as those manufactured by its industry-leading strategic partners. SES provides a complete continuum of security, defense and risk management products and support services to various governments and the private sector. (www.secures.ca)

iFinancial Management (www.ifmgmt.com) and Inter maritime Financial (www.intermaritime.ca), are two financial institutions that Mr. Khozan chairs.

He serves on the board of directors of 12 corporations in USA, Canada, Switzerland, UK, UAE, Kenya, South Africa, China and Sri Lanka, as well as overseeing the Khozan family’s multifaceted and diverse investment portfolio.

From 1984 to 1992, Mr. Khozan was the Commissioner for the Canadian Federal Government’s Lead Project, Centers of Excellence. During this period, he established an industrial Centers of Excellence in Ontario, known as Industrial Research and Development Institute (IRDI), which continues to operate successfully to date. The Center acts as the focal point for a variety of state-of-the-art technologies in Net Shape manufacturing and is a successful example of co-operation between various industries, three levels of government and a number of universities in Canada.

From 1992 to 1998 he served with the Ontario Ministries of Solicitor General and Community Safety and Correctional Services.

He is a graduate of McGill University, with Honours, cum laude, in Economics, and attained his Master’s degree in Jurisprudence and Criminology as a Distinguished Scholar, from University of Toronto.

Kamran M. Khozan has over 30 seminal patents in vapour metallurgy, all of which are in use by CVMR® today. He has over 25 years of experience in conducting seminars at various colleges and universities in Canada on entrepreneurship, corporate law and management. He has many published articles, on various topics concerning business administration and international trade. He is an honorary member of the Chippewa Ojibwa North American Native Band in Canada and a Political Consultant to that Band.



John R. Finley

John R. Finley, QC, Board of Directors and Corporate Secretary to CVMR® Group of Companies.



Michael Hargett

President and Board of Directors of CVMR® (USA) Inc.



John D. Wagoner,

John D. Wagoner, Board of Directors of CVMR® (USA) Inc.

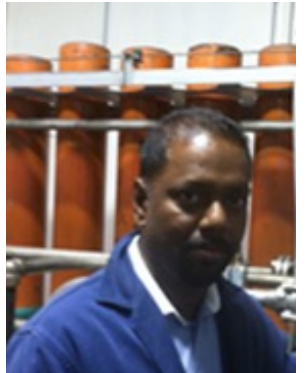

Nanthakumar Victor Emmanuel

P. Eng., Vice President, and Chief Operating Officer of CVMR® Group of Companies



Jason Hoke, MS

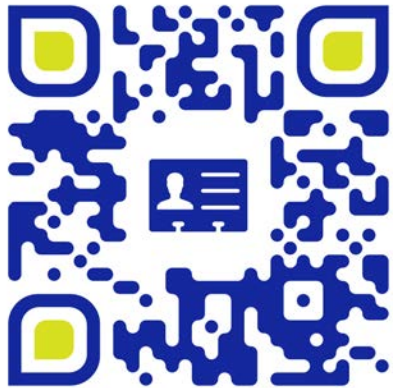

SCAN FOR CONTACT INFO

Currently, Jason is the Alaska General Manager for CVMR-Alaska. He recently joined the team after leaving a long stretch of public service. The most recent was as the Presidential Appointee of Federal Chair of the Denali Commission...

Jason served as Executive Director of Copper Valley Development Association, the regional ARDOR for the Copper Valley Region, and currently serves as President of the Board. He has been the President of the Board for the Alaska Partnership for Economic Development, and a Board Director/ Treasurer of the Board of Copper Valley Telecom. He is also a member of the AK Food Policy Council, served on the Alaska Energy Authority (AEA) Steering Committee for Biomass Greenhouses, and heading the Regional Energy Planning for the Copper Valley with AEA, Statewide Energy Planning, and Alaskan Statewide Comprehensive Economic Development Strategy Steering Committee member. Jason was a Tribal Energy Ambassador with the Department of Energy. He also served as the Treasurer of the Board for the Local Emergency Planning Commission. Jason was also invited to the White House Rural Council Conference in Washington, D.C. in 2014 as the Alaskan Delegate.

Additionally, Jason was the Programs Director for Ahtna Inter-Tribal Resource Commission. He worked on the Department of Energy- Office of Indian Energy Tribal Energy Planning. Jason also works with the natural resources of biomass and energy potentials for the region, State and tribes. Additionally, he planned and managed the food, fuel and jobs goals of biomass harvest planning, early succession planning/ moose browse enhancement, biomass utilization, and job creation within these parameters.

Mr. Hoke came to the Copper Valley, Alaska in 1996 as a teacher and administrator in Chistochina for the Copper River School District and has served in education for many years. He has a Bachelors of Arts in Sociology/Criminology, Masters of Science in Special Education/ Behaviorism, and Post-Graduate work and research in Behavioral Psychology. Jason has founded and established School and Community Supports, a non-profit agency that serves adults and children with disability throughout the Northeast. Additionally, he has owned private sector businesses, served as the Tribal Administrator for Cheesh'na Tribal Council, and has experience working with federal, state, municipal, tribal, and private entities throughout the United States, in a multitude of capacities. Jason lives with his wife and three children in rural Alaska, the Copper River Valley.

Why CVMR®

PUBLICATIONS & RESOURCES

SECTION 05

Environmental Management Site-Specific Advisory Board to the U.S. Department of Energy

Environmental Management Site-Specific Advisory Board –
April 22-23, 2015 Meeting Minutes

Pg.8 Presentations: Chairs Round Robin: Chairs' Site Reports
David Hemelright, Oak Ridge Site-Specific Advisor Board, Chair

Pg.27 Waste Disposition: Removing Contamination From Nickle
Mr. Marcinoski, DOE-EM Headquarters, Deputy Assistant Secretary for Waste Management

https://www.energy.gov/sites/prod/files/2015/08/f25/SSAB%20Meeting%20Summary%20for%20April%202015.FINAL_.pdf

News Release: TN Economic and Community Development

Governor Haslam, Commissioner Boyd Announce CVMR to Establish Global Headquarters in Oakridge. *Advanced Materials Manufacturer to Invest \$313 Million to create 620 jobs.*

Erin Holt, TNECD

<http://www.oakridgetn.gov/images/uploads/Documents/DOC491.PDF>

ALTERNATIVE METALS STUDY - United States Mint

ALTERNATIVE METALS STUDY Contract Number: TM-HQ-11-C-0049 FINAL REPORT August 31, 2012 Submitted to: United States Mint 801 Ninth Street, NW Washington, DC 20220. Contracting Officer Josephine Stanton, 202-354-7425, Josephine.Stanton@usmint.treas.gov. Contracting Officer Representatives . Richard R. Robidoux, 202-354-7514,

<https://www.usmint.gov/wordpress/wp-content/uploads/2016/06/ctcr-alternative-metals-study-2012-08-31.pdf>

CVMR: Helping to Revitalize American Manufacturing Competitiveness

DOE: Energy Efficiency and Renewable Energy
Amped Up!; Volume 1, No. 3, May/June 2015, Page 3

https://www.energy.gov/sites/default/files/2015/09/f26/amped_up_vol_1_issue_3.pdf

Direct Reduction of Waste through Refining of DOE Metal Assets -13632 Chemical Vapour Metal Refining (CVMR®)

PDF | CVMR® presents a technology for refining nickel from the enrichment barrier materials of the DOE that is proven through 100 years of use by the... | Find, read and cite all the research ...

https://www.researchgate.net/publication/309414952_Direct_Reduction_of_Waste_through...

Views on Practical Approaches to Recycling Used Fuel - CVMR

Emory D. Collins. Oak Ridge National Laboratory. collinsed@ornl.gov. 2 Managed by UT-Battelle for the U.S. Department of Energy A Practical Solution to Used Nuclear Fuel Treatment to Enable Sustained Nuclear Energy and Recovery of Vital Materials Report No.: ORNL/TM-2010/81. Date: April 2010.

cvmr.ca/video/collins.pdf

Converting Captured CO2 to Graphene

<https://cvmr.newswire.com/news/converting-captured-co2-to-graphene-20643377>

WM2011 Conference, February 27 - CVMR

UNF cladding contains one radioactive isotope, zirconium-93, formed by neutron capture on natural zirconium-92 during irradiation. Therefore, the potentially recovered zirconium would be radioactive; however, the zirconium-93 has a low specific activity (half-life is 1.5 million years) and only a weak beta emission.

www.cvmr.ca/video/zirconium.pdf

CVMR References & Publications

<http://cvmr.ca/publication.php#>

CVMR Succeeds in the Production of Self-Assembled Graphene Structures

PRNewswire

<https://www.benzinga.com/pressreleases/20/04/n15920317/cvmr-succeeds-in-the-production-of-self-assembled-graphene-structures>

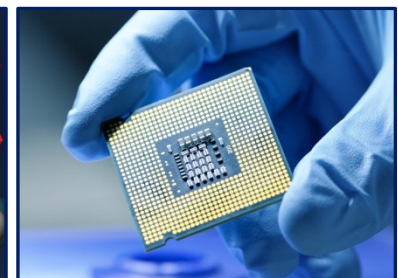
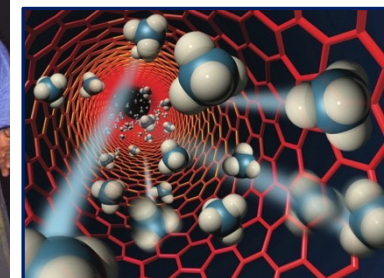
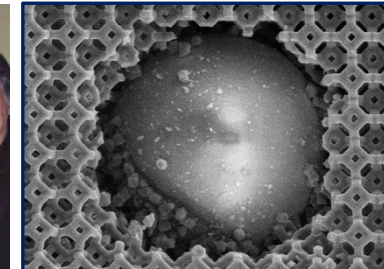

Third Party Resources

Innovations in Nano Nickel Market to Access Global Industry Players like CVMR Corporation, Eprui Nanoparticles & Microspheres, QuantumSphere (QSI), Toho, Daiken, Guangbo Shield

<https://thenanoshield.com/innovations-in-nano-nickel-market-to-access-global-industry-players-like-cvmr-corporation-eprui-nanoparticles-microspheres-quantumsphere-qi-toho-daiken-guangbo/>

Nano Nickel Market Size, Key Player Revenue, SWOT, PEST & Porter's Analysis For 2021–2027: CVMR Corporation, Eprui Nanoparticles & Microspheres, JFE Steel Corporation, Sumitomo, QuantumSphere (QSI), Toho, Daiken, Flance (Beijing) Nanotechnology
Sanjay

<https://manometcurrent.com/nano-nickel-market-size-key-player-revenue-swt-pest-porters-analysis-for-2021-2027-cvmr-corporation-eprui-nanoparticles-microspheres-jfe-steel-corporation-sumitom/?amp=1>

Nano Nickel Market 2021 Strategic Assessments – CVMR Corporation, Eprui Nanoparticles & Microspheres, JFE Steel Corporation, Sumitomo
Tanmay

<https://www.mccourier.com/nano-nickel-market-2021-strategic-assessments-cvmr-corporation-eprui-nanoparticles-microspheres-jfe-steel-corporation-sumitomo/>

Global Nano Nickel Sales Market by Type ((Ni)-20nm, (Ni)-50nm, (Ni)-80nm, (Ni)-100nm, Other), By Application (Ferrofluids, Catalysts, Conductive Pastes, Sintering Additives, Capacitor Materials, Other) and Region (North America, Latin America, Europe, Asia Pacific and Middle East & Africa), Forecast To 2028

<https://dataintelo.com/report/global-nano-nickel-sales-market/>

Powder Metallurgy Review: The magazine for the PM industry

Powder Metallurgy Review: The magazine for the PM industry

Spring 2017 Vol 6 No 1

Page 43: Carbonyl Nickel Powder Production

<https://www.pm-review.com/wp-content/uploads/2017/03/MAGAZINE-PMR-Spring-2017-PDF...>

Graphene Battery Market Worth \$609 Million by 2030 - Exclusive Report by MarketsandMarkets(TM)

<https://www.epicos.com/article/531592/graphene-battery-market-worth-609-million-2030-exclusive-report-marketsandmarketstm>

Graphene Producers: CVMR Corporation (Company Profile)

Graphene Info–The Graphene Experts

<https://www.graphene-info.com/cvmr-corporation>

Cvmr Corporation (CVMR®) Announced a Major Breakthrough in the Development of Their Off the Grid Power Generating System.

TORONTO (PRWEB) May 19, 2018

<https://www.streetinsider.com/dr/news.php?id=14216054&gfv=1>

Direct extraction of nickel and iron from laterite ores using the carbonyl process

Terekhov and Emmanuel

<https://www.sciencedirect.com/science/article/abs/pii/S0892687513002264>



The Federal Tax ID: 46-4558923.
DUNS: 826935160
SAM No: 826935160
CAGE Code: 83G80

2022 NAICS

- 335910 Battery Manufacturing.
- 325315 Compost Manufacturing
- 541713 Research and Development in Nanotechnology
- 333242 Semiconductor Machinery Manufacturing
- 3344 Semiconductor and Other Electronic Component Manufacturing
- 212230 Copper, Nickel, Lead, and Zinc Mining Or 21223
- 562920 Materials recovery facilities (MRF)
- 333249 Other Industrial Machinery Manufacturing
- 562920 Materials Recovery Facilities
- 92711 Space Research and Technology
- 213115 Support Activities for Nonmetallic Minerals (except Fuels) Mining
- 331511 Iron Foundries
- 236220 Commercial and Institutional Building Construction
- 324199 All Other Petroleum and Coal Products Manufacturing
- 3364 Aerospace Product and Parts Manufacturing
- 42351 Metal Service Centers and Other Metal Merchant Wholesalers
- 4931 Warehousing and Storage
- 541380 Testing Laboratories and Services
- 334516 Electron microscopes manufacturing

**DEMONSTRATED & PROVEN
TECHNOLOGIES FOR OVER
36 YEARS**

**An Environmentally Neutral Critical
Minerals Refinery Network in U.S.**



[cvmr]
ALASKA

